

**Standard Construction and Materials**

**FRAME:** .081" thk. (nominal) extruded aluminum, 6063-T52/T6 alloy. Channel type.

**BLADE:** .081" thk. (nominal) extruded aluminum 6063-T52/T6 alloy. Blades are approximately 4½" on centers.

**LOUVER FACE:** Full width sill with drain head and drain blades contained within drain jambs.

**SHAFT:** .50" dia aluminum "Pin-Lock" rod.

**BEARINGS:** Celcon bearing material so that there will be no metal to metal friction.

**LINKAGE:** Extruded aluminum, concealed in the channel out of the airstream. The pivots, which rotate in Celcon bearings, are .50" dia. plated and machined steel. The pivot is locked to the 5/16" dia. aluminum linkage rod by a ¼ - 20 set screw with epoxy locking patch.

**SEALS:** Extruded silicone rubber seals at blade edge. Polyurethane at jambs.

**SCREEN:** (When indicated, in a removable frame) ½" flattened aluminum, .051" thk.,

- or- ½" sq. mesh intermediate double crimped aluminum wire, .063" dia.,
- or- 18/16 aluminum mesh insect screen, .011" dia.

**FINISH:** Mill.

**ACTUATOR:** 120 VAC spring return normally closed. 133 in-lbs. torque.

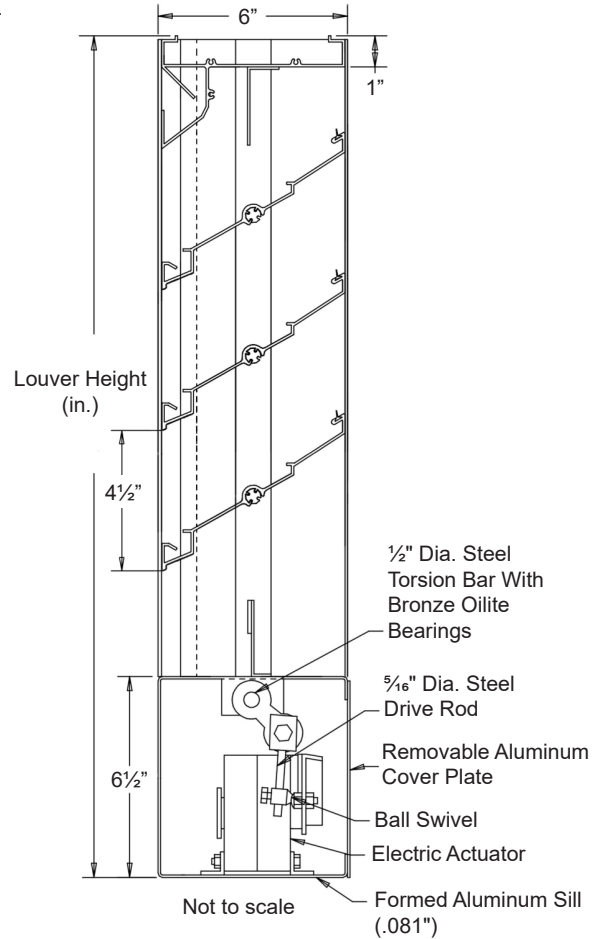

**Options**

Finishes - Enamels, Epoxies, etc.  
Other screens also available.

**Notes**

1. Nominal deductions will be made to the opening size given.
2. Approximate shipping weight is 5.6 lbs./sq.ft.

**Louver Sizes**

Min Panel	Max Single Panel
12"W x 19"H	48"W x 96"H

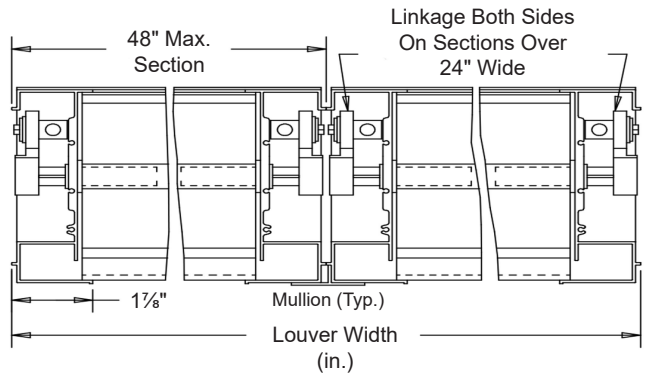

Item #	Qty	Width	Height	Width	Height	Mullion	Type	Location	Union Made
		Opening Size		Louver Size			Screens		
Arch. / Eng.:						EDR:		ECN:	Job:
Contractor:									
Project:						Date:		DWN:	DWG:

In the interest of product development, CESCO Products reserves the right to make changes without notice.



450 Riverside Dr • Wyalusing PA, 18853  
Phone: 570-746-1888 • Fax: 570-746-9286  
www.cescoproducts.com